

# General presentation of Eurocode 7 on 'Geotechnical design'

FRANK, R. Université Paris-Est, Ecole des Ponts, Lab Navier-Geotechnical group (CERMES)

**ABSTRACT:** Eurocode 7 on 'Geotechnical design' is now being used in many countries throughout Europe. Part 1 devoted to the 'General rules' has been published in 2004. National Annexes and accompanying documents have been prepared for implementation in the various European countries. Part 2 on 'Ground investigation and testing' was published in 2007. In 2015, the drafting of a revised version was launched. After describing shortly the history of the development of Eurocode 7, the contents of the two present documents are given and the main concepts are described (verification procedures and geotechnical categories, characteristic values, derived values, ULS verifications, SLS verifications and allowable movements of foundations).

## 1. INTRODUCTION

The system of Structural Eurocodes includes 10 following sets of standards (EN for 'European Norm'):

- EN 1990 Eurocode: Basis of structural design
- EN 1991 Eurocode 1: Actions on structures
- EN 1992 Eurocode 2: Design of concrete structures
- EN 1993 Eurocode 3: Design of steel structures
- EN 1994 Eurocode 4: Design of composite steel and concrete structures
- EN 1995 Eurocode 5: Design of timber structures
- EN 1996 Eurocode 6: Design of masonry structures
- EN 1997 Eurocode 7: Geotechnical design
- EN 1998 Eurocode 8: Design of structures for earthquake resistance
- EN 1999 Eurocode 9: Design of aluminium structures

The Structural Eurocodes are design codes for buildings and civil engineering works. They are based on the Limit State Design (LSD) approach used with a partial factor method.

Except for EN 1990, all Eurocodes are subdivided into several parts. Eurocodes 2, 3, 4, 5, 6 and 9 are 'material' Eurocodes, i.e. relevant to a given material. EN 1990 (Basis of design), Eurocode 1 (Actions), Eurocode 7 (Geotechnical design) and Eurocode 8 (Earthquake resistance) are relevant to all types of construction, whatever the material.

Altogether, 58 parts in total have been published and the official deadline for withdrawing all conflicting national standards was April 2010.

Eurocode 7 should be used for all the problems of interaction of structures with the ground (soils and rocks), through foundations or retaining structures. It addresses not only buildings but also bridges and other civil engineering works. It allows the calculation of the geotechnical actions on the structures, as well the resistances of the ground submitted to the actions from the structures. It also gives all the prescriptions and rules for good practice required for properly conducting the geotechnical aspect of a structural project or, more generally speaking, a purely geotechnical project.

Eurocode 7 consists presently of two parts:

- EN 1997-1 Geotechnical design - Part 1: General rules (CEN, 2004, 2013)
- EN 1997-2 Geotechnical design - Part 2: Ground investigation and testing (CEN, 2007)

After describing shortly the history of the development of Eurocode 7, and giving the main contents of the two parts, the main concepts are described, without recalling all the principles of LSD and of the partial factor method used.

## 2. HISTORY OF EUROCODE 7 AND IMPLEMENTATION

The first Eurocode 7 Group, in charge of drafting an European standard on geotechnical design, was created in 1981. It was composed of representatives of the Member Societies of the International Society for Soil mechanics and Geotechnical Engineering (ISSMGE) of the 10 countries forming the European Community at that time. A first model code on general rules for geotechnical design (corresponding to Eurocode 7- Part 1) was published in 1990 (EC7, 1990).

In 1990, the task of drafting design codes for buildings and civil engineering works was transferred to the Comité Européen de Normalisation (CEN, European Committee for Standardization) and CEN/TC 250 (Technical Committee 250) in charge of all the 'Structural Eurocodes' was created. In particular, SC 7, Sub-Committee 7, is in charge of Eurocode 7 on 'Geotechnical design'. Note that CEN is composed of the national standard bodies of a number of European countries (since 2017, 34 countries are members, i.e. the present 28 countries of EU, plus 3 countries of EFTA, FYR Macedonia, Serbia and Turkey). N. Krebs Ovesen (Denmark) was the first Chairman of CEN/TC 250/SC 7, from 1990 until 1998. The author was the Chairman of SC 7 from 1998 to 2004. From 2004 to 2010, Bernd Schuppener (Germany) was the Chairman. The new Chairman, since 2010, is Andrew Bond (UK).

In 1993, SC 7 adopted the ENV 1997-1 pre-standard: 'Geotechnical design - Part 1: General Rules' (CEN, 1994). It was clear, at that time, that (much) more work still needed to be done before reaching a full European standard (EN) acceptable to all members of CEN. An important fact helped in obtaining, in 1997, a positive vote for the conversion into an EN. It was the recognition by CEN/TC 250 that geotechnical design is unique and cannot be considered to be the same as other design practices needed in the construction industry. The models commonly used vary from one country to the other and cannot be harmonised easily, simply because the geologies are different and form the rationale for the so-called 'local traditions'... This recognition is confirmed by a resolution taken by TC 250 (Resolution N 87, 1996): '*CEN/TC 250 accepts the principle that EN 1997-1 might be devoted exclusively to the fundamental rules of geotechnical design and be supplemented by national standards*'.

The work for the conversion of ENV 1997-1 into EN 1997-1 'Geotechnical design – Part 1: General rules' was performed from 1997 to 2003. The formal positive vote by CEN members was obtained early 2004 and CEN finally published Eurocode 7 – Part 1 (EN 1997-1) in November 2004 (CEN, 2004).

Two other ENVs, devoted to geotechnical design assisted by laboratory testing and by field (in situ) testing were drafted rather quickly, facing no serious controversy. They were published in 1999 (CEN, 1999a and 1999b) and, in 2001, the members of CEN voted positively for their conversion into a European Norm. During the conversion phase, the two documents were merged into the single document called 'Eurocode 7 Geotechnical design - Part 2: Ground investigation and testing'. The formal positive vote was obtained in May 2006 and the document was published in March 2007 (CEN, 2007).

The publication of a Eurocode Part by each national standardisation body with its National Annex (in the official language(s) of the country) had to be completed within two years after publication by CEN. The role of the National Annex is to indicate the decisions corresponding to the so-called "Nationally Determined Parameters (NDPs)" (like values of partial factors, choice of Design Approach, status of informative Annexes, etc. – see below).

The 'legal' status of standards/norms is different in each country and the regulatory bodies of the various countries have an important role to play for the implementation of the Eurocodes. A 'Guidance Paper' has been elaborated by the European Commission to co-ordinate the implementation of the

Eurocodes into the national regulations (EC, 2003a). The European Commission has also issued a strong recommendation to the Member States inviting them to adopt the Eurocodes in their regulations (EC, 2003b). The paper by Anagnostopoulos and Frank (2012) gives more details about all the implementation process.

In 2015, the drafting of the 'Second Generation of Structural Eurocodes' was launched by CEN with the support of the European Commission. The documents consisting of the whole set of revised structural Eurocodes should be ready around 2022 and the implementation in the various countries could follow shortly afterwards. With regard to Eurocode 7, it is intended to organise the revised code in three parts. Part 1 would include and extend all the general rules included in the present Part 1. Part 2 would remain essentially the same as the present Part 2. Part 3 will be created from the sections of the present Part 1 dealing with specific geotechnical structures and will include more details on the design of some of them, as well as on the design with rocks. The various sections would then deal respectively with: Slopes, cuttings, and embankments, Spread foundations, Pile foundations, Retaining walls, Anchors, Reinforced soil structures and Ground improvement.

### 3. CONTENTS OF THE PRESENT DOCUMENTS

#### 3.1 Part 1: General rules

Eurocode 7 - Part 1 is a rather general document giving only the principles for geotechnical design inside the general framework of LSD. These principles are relevant to the calculation of the geotechnical actions on structures (buildings and civil engineering works) and to the design of the structural elements themselves in contact with the ground (footings, piles, basement walls, etc.). Detailed design rules or calculation models, i.e. precise formulae or charts are only given in informative Annexes. As already mentioned, the main reason is that the design models in geotechnical engineering differ from one country to the other, and it was not possible to reach a consensus, especially when many of these models still need to be calibrated and adapted to the LSD approach...

Eurocode 7 – Part 1 includes the following sections (CEN, 2004, 2013):

- Section 1 General
- Section 2 Basis of geotechnical design
- Section 3 Geotechnical data
- Section 4 Supervision of construction, monitoring and maintenance
- Section 5 Fill, dewatering, ground improvement and reinforcement
- Section 6 Spread foundations
- Section 7 Pile foundations
- Section 8 Anchors
- Section 9 Retaining structures
- Section 10 Hydraulic failure
- Section 11 Overall stability
- Section 12 Embankments

A number of Annexes are included. They are all informative, except for Annex A which is 'normative' (i. e. mandatory). The list of the Annexes of EN 1997-1 is the following:

- Annex A (normative) Partial factors for ultimate limit states
- Annex B Background information on partial factors for Design Approaches 1, 2 3
- Annex C Sample procedures to determine limit values of earth pressures on vertical walls
- Annex D A sample analytical method for bearing resistance calculation
- Annex E A sample semi-empirical method for bearing resistance estimation
- Annex F Sample methods for settlement evaluation
- Annex G A sample method for deriving presumed bearing resistance for spread foundations on rock
- Annex H Limiting foundation movements and structural deformation
- Annex J Checklist for construction supervision and performance monitoring

Annex A is important, as it gives the partial factors for ULS in persistent and transient design situations (fundamental combinations), as well as correlation factors for the characteristic values of pile bearing capacity. But the numerical values for the partial or correlation factors given in Annex A are only recommended values. The exact values of the factors can be changed by each national standardisation body in the so-called National Annex. All other Annexes are informative (i. e. not mandatory in the normative sense). Some of them, though, contain valuable material which can be accepted, in the near future, by most of the countries. The National Annex can give a 'normative(s)' status to one or to several of the 'informative' Annexes, i.e. it (they) are mandatory in the corresponding country.

As mentioned above, each country is also free to supplement the general rules of Eurocode 7 by national application standards, in order to specify the calculation models and design rules to be applied in the country. Whatever their contents they have to respect in all aspects the principles of Eurocode 7. In France, for instance, 5 national standards have been issued for the application of Eurocode 7. They deal with the design of embedded walls, of reinforced and soil nailing retaining structures, deep foundations, shallow foundations and gravity walls, respectively (AFNOR, 2009a, 2009b, 2012, 2013 and 2014)

### 3.2 Part 2: Ground investigation and testing

The role of this part of Eurocode 7 devoted to laboratory and field testing is to give the essential requirements for the equipment and test procedures, for the reporting and the presentation of results, for their interpretation and, finally, for the derivation of values of geotechnical parameters for the design. It complements the requirements of Part 1 in order to ensure a safe and economic geotechnical design.

It makes the link between the design requirements of Part 1, in particular Section 3 'Geotechnical data', and the results of a number of laboratory and field tests.

It does not cover the standardisation of the geotechnical tests themselves. Another Technical Committee (TC) on 'Geotechnical investigation and testing' has precisely been created by CEN to consider this matter (TC 341). In this respect the role of Part 2 of Eurocode 7 is to 'use' and refer to the detailed rules for test standards covered by TC 341.

Eurocode 7 – Part 2 includes the following Sections (CEN, 2007):

Section 1 General

Section 2 Planning of ground investigations

Section 3 Soil and rock sampling and groundwater measurements

Section 4 Field tests in soils and rocks

Section 5 Laboratory tests on soils and rocks

Section 6 Ground investigation report

The Section on field tests in soils and rocks includes:

- cone penetration tests CPT(U)
- pressuremeter tests PMT
- rock dilatometer tests RDT
- standard penetration tests SPT
- dynamic penetration tests DP
- weight sounding tests WST
- field vane tests FVT
- flat dilatometer tests DMT
- plate loading tests PLT

The Section on laboratory testing of soils and rocks deals with:

- preparation of soil specimens for testing
- preparation of rock specimens for testing
- tests for classification, identification and description of soils
- chemical testing of soils and groundwater

- strength index testing of soils
- strength testing of soils
- compressibility and deformation testing of soils
- compaction testing of soils
- permeability testing of soils
- tests for classification of rocks
- swelling testing of rock material
- strength testing of rock material

There are provisions on how to establish and use the so-called 'derived values' from the tests (see paragraph 4.3 below). Some of these provisions are meant to give guidance for using the sample calculation models in the Annexes of Part 1. Part 2 also includes a number of informative Annexes with precise examples of derived values of geotechnical parameters and coefficients commonly used in design.

As is the case in Part 1, most of the derivations or calculation models given are informative, but there is also fairly good agreement about using them in the future throughout Europe. In any case, they are a clear picture of the approaches existing on the continent for the use of *in situ* or laboratory test results in the design of geotechnical structures.

## 4. SOME ASPECTS OF EUROCODE 7

### 4.1 Verification procedures and geotechnical categories

The discussions about verifications of geotechnical design usually focus on approaches performed through calculations. Nevertheless, it should be stressed that calculations are not the only means for checking that the basic requirements are fulfilled.

Eurocode 7 – Part 1 offers, in fact, various possibilities (clause 2.1 in EN 1997-1):

*'(4) Limit states should be verified by one or a combination of the following:*

- *use of calculations [...];*
- *adoption of prescriptive measures, [...];*
- *experimental models and load tests, [...];*
- *an observational method, [...].'*

This paragraph is clear enough. However, it may be useful to add that:

- the adoption of prescriptive measures indicates that, in some circumstances (see the geotechnical categories below), one may avoid calculations which may look long and cumbersome with regard to the problem under consideration ;
- the use of experimental models and load tests recalls that the fundamentals of geotechnical design and of its calculation rules are the monitoring of the behaviour of real structures, with recourse, when necessary, to full scale tests ;
- finally, mentioning the observational method, shows one of the directions devoted to contemporary geotechnical design (with full consistency with the fundamentals mentioned above).

With regard to the observational method (or 'interactive design'), Eurocode 7 adds that (clause 2.7 in EN 1997-1):

*'(2)P The following requirements shall be met before construction is started:*

- *acceptable limits of behaviour shall be established;*
- *the range of possible behaviour shall be assessed and it shall be shown that there is an acceptable probability that the actual behaviour will be within the acceptable limits;*
- *a plan of monitoring shall be devised, which will reveal whether the actual behaviour lies within the acceptable limits. The monitoring shall make this clear at a sufficiently early stage, and with sufficiently short intervals to allow contingency actions to be undertaken successfully;*
- *the response time of the instruments and the procedures for analysing the results shall be sufficiently rapid in relation to the possible evolution of the system;*

— *a plan of contingency actions shall be devised, which may be adopted if the monitoring reveals behaviour outside acceptable limits.*'

(note that, in the Eurocodes, when the letter 'P' accompanies the number of a paragraph, it means that it is a principle, i.e. a fundamental requirement; paragraphs not marked with 'P' are only 'application rules').

The use of the observational method should grow considerably in the coming years (see Huybrechts et al., 2005).

In order to define the design requirements and the levels needed for the geotechnical investigation, Eurocode 7 introduces three geotechnical categories (clause 2.1 in EN 1997-1). It is a way of introducing, one can say, 'consequences classes' (see Annex B of EN 1990, CEN, 2002).

Geotechnical category 1 corresponds to the simple structures that can be designed and executed, with negligible risk, only on the basis of experience and with a qualitative geotechnical investigation. One can place in this category retaining walls of moderate height or direct foundations for individual houses, in simple geotechnical conditions (neither stability nor water problems, etc.).

Geotechnical category 2 covers conventional geotechnical structures, without exceptional risk (i.e. without difficult geotechnical conditions or loadings). Eurocode 7 requirements concerning calculations and ground investigations fully apply to category 2 geotechnical structures (clause 2.1 in EN 1997-1):

*'(18) Designs for structures in Geotechnical Category 2 should normally include quantitative geotechnical data and analysis to ensure that the fundamental requirements are satisfied.*

*'(19) Routine procedures for field and laboratory testing and for design and execution may be used for Geotechnical Category 2 designs.*

*NOTE The following are examples of conventional structures or parts of structures complying with Geotechnical Category 2:*

- *spread foundations;*
- *raft foundations;*
- *pile foundations;*
- *walls and other structures retaining or supporting soil or water;*
- *excavations;*
- *bridge piers and abutments;*
- *embankments and earthworks;*
- *ground anchors and other tie-back systems;*
- *tunnels in hard, non-fractured rock and not subjected to special water tightness or other requirements.'*

Category 3 includes all geotechnical structures with abnormal risks, for which Eurocode 7 requirements may not be sufficient to ensure an acceptable level of safety. The risks can derive from the ground conditions or from the loading conditions. Examples of structures falling into this category are large dams, foundations of nuclear power plants, structures on unstable ground, etc. Eurocode 7 clearly indicates that (clause 2.1 in EN 1997-1):

*'(21) Geotechnical Category 3 should normally include alternative provisions and rules to those in this standard [EN 1997-1].'*

In the Eurocode system, as mentioned earlier, the calculation method prescribed is the LSD approach used in conjunction with a partial factor method. Problems encountered in geotechnical engineering projects are often due to reasons not linked to design calculations. For geotechnical practice, Eurocode 7 – Part 1 also mentions that (clause 2.4.1 in EN 1997-1):

*'(2) It should be considered that knowledge of the ground conditions depends on the extent and quality of the geotechnical investigations. Such knowledge and the control of workmanship are usually more significant to fulfilling the fundamental requirements than is precision in the calculation models and partial factors.'*

## 4.2 Characteristic values

The present 'philosophy' with regard to the definition of characteristic values of geotechnical parameters is contained in the following clauses of Eurocode 7 – Part 1 (clause 2.4.5.2 in EN1997-1):

*'(2)P The characteristic value of a geotechnical parameter shall be selected as a cautious estimate of the value affecting the occurrence of the limit state.'*

*'(7) [...]the governing parameter is often the mean of a range of values covering a large surface or volume of the ground. The characteristic value should be a cautious estimate of this mean value.'*

These paragraphs in Eurocode 7 – Part 1 reflect the concern that one should be able to keep using the values of the geotechnical parameters that were traditionally used (the determination of which is not standardised, i.e. they often depend on the individual judgment of the geotechnical engineer, one should confess). However two remarks should be made at this point: on the one hand, the concept of 'derived value' of a geotechnical parameter (preceding the determination of the characteristic value), has been introduced (see Figure 1 and paragraph 4.3) and, on the other hand, there is now a clear reference to the limit state involved (which may look evident, but is, in any case, a way of linking traditional geotechnical engineering and the new limit state approach) and to the assessment of the mean value (and not a local value; this might appear to be a specific feature of geotechnical design which, indeed, involves 'large' areas or 'large' ground masses).

Statistical methods are mentioned only as a possibility:

*'(10) If statistical methods are employed [...], such methods should differentiate between local and regional sampling [...].'*

*'(11) If statistical methods are used, the characteristic value should be derived such that the calculated probability of a worse value governing the occurrence of the limit state under consideration is not greater than 5%. NOTE In this respect, a cautious estimate of the mean value is a selection of the mean value of the limited set of geotechnical parameter values, with a confidence level of 95%; where local failure is concerned, a cautious estimate of the low value is a 5% fractile.'*

The general feeling is that the characteristic value of a geotechnical parameter cannot be fundamentally different from the value that was traditionally used. Indeed, for the majority of projects, the geotechnical investigation is such that no serious statistical treatment of the data can be performed. Statistical methods are, of course, useful for very large projects where the amount of data justifies them.

#### 4.3 Derived values

Many geotechnical tests, particularly field tests, do not allow basic geotechnical parameters or coefficients, for example for strength and deformation, to be determined directly. Instead, values of these parameters and coefficients must be derived using theoretical or empirical correlations.

The concept of 'derived values' has been introduced in ENV 1997-3 (CEN 1999b), in order to give a status to correlations and models commonly used to obtain, from both results of field tests and results of laboratory tests, geotechnical parameters and coefficients which enter directly into the design. Their use is intended, primarily, for the design of pile and shallow foundations as mentioned in the Annexes D, E, F, and G of Eurocode 7 - Part 1.

The definition of derived values is given in Eurocode 7 – Part 2 as:

*'Derived values of geotechnical parameters and/or coefficients, are obtained from test results by theory, correlation or empiricism.'*

From field test results, the geotechnical parameter obtained is either an input for an analytical or indirect model, or a coefficient for use in a semi-empirical or direct model of foundation design.

Derived values of a geotechnical parameter then serve as input for assessing the characteristic value of this parameter in the sense of Eurocode 7 - Part 1 (clause 2.4.5.2 of EN 1997-1) and, further, its design value, by applying the partial factor  $\gamma_M$  ('material factor', clause 2.4.6.2).

The role played by the derived values of geotechnical parameters can be understood with the help of figure 1, taken from Eurocode 7 - Part 2. The borderline between Part 1 (EN 1997-1) and Part 2 (EN 1997-2) of Eurocode 7 is also shown on the figure. It can be seen that the requirements concerning the measurements of geotechnical properties, as well as their derived values are covered by Part 2: 'Ground investigation and testing', while those concerning the determination of characteristic values and design values are given by Part 1: 'General rules'.

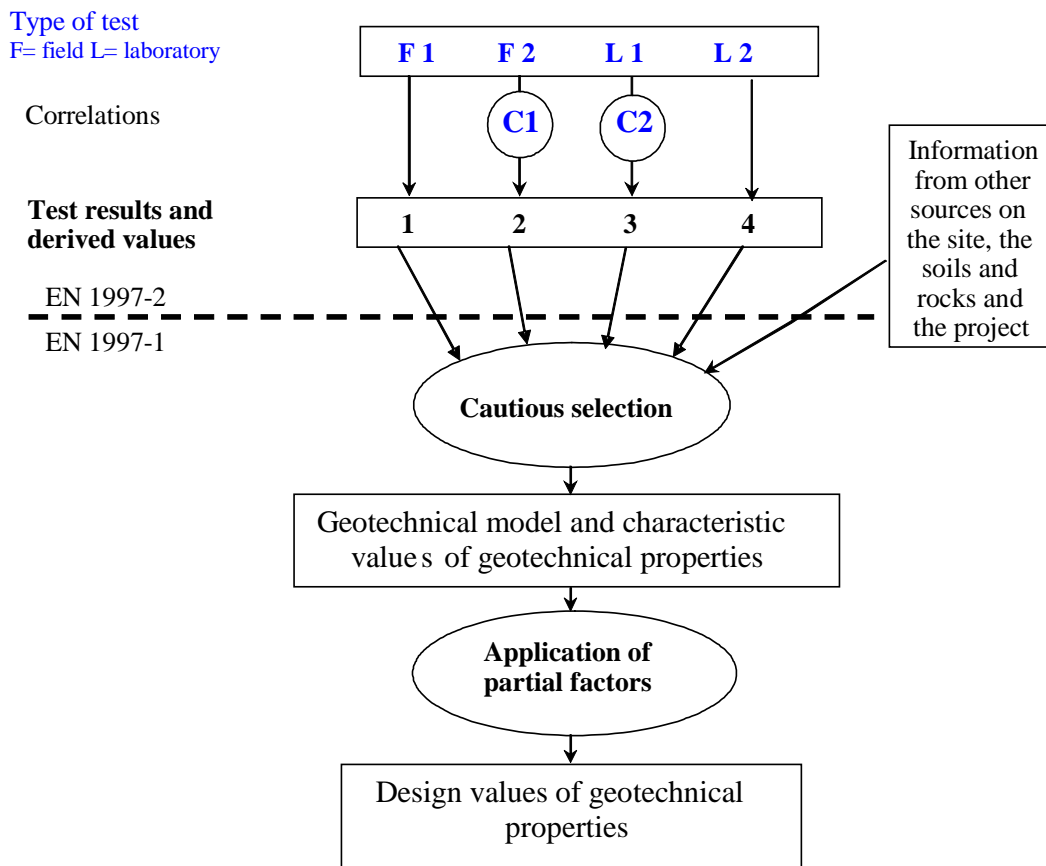

Figure. 1. General framework for the selection of derived values, characteristic values and design values of geotechnical properties (CEN, 2007)

#### 4.4 Verifications of ultimate limit states (ULS)

The ultimate limit states (ULS) to be checked are defined, in the following manner, by Eurocode 7 – Part 1, consistently with ‘Eurocode: Basis of structural design’ (CEN 2002) (clause 2.4.7.1 in EN 1997-1):

‘(1)P Where relevant, it shall be verified that the following limit states are not exceeded:

- loss of equilibrium of the structure or the ground, considered as a rigid body, in which the strengths of structural materials and the ground are insignificant in providing resistance (EQU);
- internal failure or excessive deformation of the structure or structural elements, including footings, piles, basement walls, etc., in which the strength of structural materials is significant in providing resistance (STR);
- failure or excessive deformation of the ground, in which the strength of soil or rock is significant in providing resistance (GEO);
- loss of equilibrium of the structure or the ground due to uplift by water pressure (buoyancy) or other vertical actions (UPL);
- hydraulic heave, internal erosion and piping in the ground caused by hydraulic gradients (HYD).

NOTE Limit state GEO is often critical to the sizing of structural elements involved in foundations or retaining structures and sometimes to the strength of structural elements.’

The ultimate limit states should be verified for the combinations of actions corresponding to the following design situations (see EN 1990, CEN, 2002):



- permanent and transient (the corresponding combinations are called 'fundamental'); in the following these design situations are noted 'p&tds' for convenience;
- accidental;
- seismic (see also Eurocode 8 - Part 5, i.e. EN 1998-5).

The design values of the actions and the combinations of actions are defined in EN 1990 (partial factors  $\gamma$  for the actions and factors  $\psi$  for the accompanying variable actions).

The debate about the format for checking the GEO and STR ultimate limit states (ULS) was relevant to the persistent and transient design situations ('p&tds'). This debate follows from the ENV 1997-1 (CEN, 1994) formulation which inferred that ULS in persistent and transient design situations had to be checked for two formats of combinations of actions, i.e. for Cases B and C, as they were called at that time. B was aimed at checking the uncertainty on the loads coming from the structure, and C the uncertainty on the resistance of the ground. Some geotechnical engineers were in favour of this double check, as others preferred having to use only one single format of combinations of actions (more details can be found in Frank and Magnan, 1999).

The consensus reached between structural and geotechnical engineers opened the way to three different Design Approaches (DA 1, DA 2 and DA 3). The choice is left to national determination, i.e. each country had to state in its National Annex, the Design Approach(es) to be used for each type of geotechnical structure (spread foundations, pile foundations, retaining structures, slope stability).

Generally speaking, for checking ULS- p&tds, three sets of partial factors to be applied to characteristic values of actions are introduced in EN 1990: Sets A, B, and C:

- set A is used for checking the static equilibrium of the structure (EQU);
- set B is relevant to the design of structural members (STR) not involving geotechnical actions;
- sets B and C are relevant to the design of structural members involving geotechnical actions and the resistance of the ground (STR/GEO).

Tables 1, 2 and 3 give, in a simplified manner, the recommended values for buildings for Sets A, B and C, taken from Tables A1.2 (A), A1.2(B) and A1.2(C) of EN 1990 (CEN, 2002). The recommended values given may be modified by National decision.

For STR/GEO ULS in p&tds, the three Design Approaches are the following (clause A1.3.1 in EN 1990):

*'(5) Design of structural members (footings, piles, basement walls, etc.) (STR) involving geotechnical actions and the resistance of the ground (GEO) should be verified using one of the following three approaches supplemented, for geotechnical actions and resistances, by EN 1997:*

*Approach 1: Applying in separate calculations design values from Table A1.2(C) and Table A1.2(B) to the geotechnical actions as well as the other actions on/from the structure. In common cases, the sizing of foundations is governed by Table A1.2(C) and the structural resistance is governed by Table A1.2(B); Note: In some cases, application of these tables is more complex, see EN 1997.*

*Approach 2: Applying design values from Table A1.2(B) to the geotechnical actions as well as the other actions on/from the structure;*

*Approach 3: Applying design values from Table A1.2(C) to the geotechnical actions and, simultaneously, applying partial factors from Table A1.2(B) to the other actions on/from the structure.*

*Note: The use of approaches 1, 2 or 3 is chosen in the National annex.'*

In other words, Design Approach 1 (DA1) is the double check procedure coming from the ENV 1997-1 (B+C verifications) and Design Approaches 2 (DA 2) and 3 (DA 3) are new procedures using a single format of combinations of actions. DA 2 is elaborated with 'resistance factors' for the ground (RFA), as DA 3 makes use of 'material factors' for the ground (MFA).

With regard to the choice between expression 6.10 or expressions 6.10a and 6.10b of EN 1990 (see table 2 for set B), Eurocode 7 only mentions the recommended values of the factors corresponding to expression 6.10 (table A.3 in the note to paragraph A.3(1)P of Annex A in EN 1997-1). This derives from the fact that the recommended geotechnical values come from a few calibration studies performed using the values of expression 6.10, while, on the other hand, there is no experience on the use of expressions 6.10a et 6.10b in geotechnical engineering...

Table 1. Recommended values for partial factors for actions (Set A) after EN 1990 (CEN, 2002) – ULS in p&tds

Action	Symbol	Value
Permanent actions		
- unfavourable	$\gamma_{G,sup}$	1.10 <sup>(1)</sup>
- favourable	$\gamma_{G,inf}$	0.90 <sup>(1)</sup>
Variable actions		
- unfavourable	$\gamma_Q$	1.50
- favourable		0

(1) As an alternative, the favourable part may be multiplied by  $\gamma_{G,inf} = 1.15$  and the unfavourable part by  $\gamma_{G,sup} = 1.35$

Table 2. Recommended values for partial factors for actions (Set B) after EN 1990 (CEN, 2002) – ULS in p&tds

Action	Symbol	Value	
		Eq. (6.10)	Eq. (6.10a) / Eq. (6.10b)
Permanent			
-unfavourable <sup>(1)</sup>	$\gamma_{Gsup}$	1.35	1.35 / 1.15 <sup>(2)</sup>
- favourable <sup>(1)</sup>	$\gamma_{Ginf}$	1.00	1.00 / 1.00
Variable			
- unfavourable	$\gamma_Q$	1.50	1.50 / $1.5\psi_0$
- favourable		0	0 / 0

(1) all permanent actions from one source are multiplied by  $\gamma_{Gsup}$  or by  $\gamma_{Ginf}$ .

(2) value of  $\xi$  is 0.85, so that  $0.85\gamma_{Gsup} = 0.85 \times 1.35 \cong 1.15$ .

Note 1 : choice between expression 6.10 or expressions 6.10a and 6.10b used together, is by National decision

Note 2:  $\gamma_G$  and  $\gamma_Q$  may be subdivided into  $\gamma_g$  and  $\gamma_q$  and the model uncertainty factor  $\gamma_{Sd}$ .  $\gamma_{Sd} = 1.15$  is recommended.

Table 3. Recommended values for partial factors for actions (Set C) after EN 1990 (CEN, 2002) – ULS in p&tds

Action	Symbol	Value
Permanent actions		
- unfavourable	$\gamma_{G,sup}$	1.00
- favourable	$\gamma_{G,inf}$	1.00
Variable actions		
- unfavourable	$\gamma_Q$	1.30
- favourable		0

Furthermore, Eurocode 7 allows applying the partial factors either on the actions themselves ("at the source") or on the effects of the actions (they are noted  $\gamma_F$  and  $\gamma_E$ , respectively). In principle, for DA 1 they are applied "at the source". For DA 2 and DA 3, both options are allowed. This is relevant to the factors of set B and of set C (unfavourable variable actions).

Table 4 gives the link between Sets B and C and the corresponding sets of factors for geotechnical actions and resistances: Sets M1 and M2 for material properties (e.g.  $c'$ ,  $\phi'$ ,  $c_u$ , etc.) and Sets R1, R2, R3 and R4 for total resistances (e.g. bearing capacity, etc.). These sets are defined in Annex A of Eurocode 7 – Part 1. As mentioned above, Annex A also gives recommended values for the partial factors; these values may be set differently by the National Annex. Note that the recommended values for the partial factors  $\gamma_M$  on material properties in Set M1 are always equal to 1.0.

Table 4. STR/GEO – ULS in p&tds. Partial factors to be used according to EN 1990 and EN 1997-1

Design Approach	Actions on/from the structure	Geotechnical	
		Actions	Resistances
1	B	B and M1	M1 and R1
	C	C and M2	M2 and R1 or M1 and R4*
2	B	B and M1	M1 and R2
3	B	C and M2	M2 and R3

\*for piles and anchorages

In DA 1, the first format (combination 1, former case B) applies safety mainly on actions, while the factors on resistances have recommended values equal to 1.0 (Sets M1 and R1) or near 1.0 (Set R1 in the case of axially loaded piles and anchorages); in the second format imposed by DA 1 (combination 2, former case C), the elementary properties of the ground (shear strength parameters) are always factored for the calculation of geotechnical actions and sometimes factored for the calculation of resistances (Set M2); in the case of axially loaded piles and anchorages, the total resistance is directly factored by applying Set R4.

In DA 2, safety is applied both on the actions (Set B) and on the total ground resistance (Set R2).

In DA 3, safety is applied both on the actions (Set B for the actions coming from the structure and Set M2 for the elementary properties of the ground acting on the structure, i.e. for the geotechnical actions) and on the geotechnical resistances (Set M2 for the elementary properties; the recommended values for Set R3 for the total geotechnical resistance is always equal to 1.0, except for piles in tension and anchorages for which they are equal to 1.1).

Figures 2, 3 and 4, as well as their captions, illustrate the situation for each of the three Design Approaches. On these figures, index 'd' indicates a design value different from the characteristic value (application of a partial factor  $\gamma$  different from 1.0) and index 'k' indicates a design value equal to the characteristic value (application of a partial factor  $\gamma$  equal to 1.0).

It should be mentioned that 'model factors' can also be introduced (clause 2.4.7.1 in EN 1997-1): *'(6) When calculating the design value of the resistance, ( $R_d$ ), or the design value of the effect of actions, ( $E_d$ ), model factors, ( $\gamma_{R;d}$ ) or ( $\gamma_{S;d}$ ) respectively, may be introduced to ensure that the results of the design calculation model are either accurate or err on the safe side.'* An example of the use of a model factor for the bearing capacity of piles is given by Burlon et al. (2014)

More details on the use of the three Design Approaches are given, for instance, in Frank et al. (2004).

With regard to the design values for accidental situations, Eurocode 7 only states that (clause 2.4.7.1 in EN 1997-1):

*'(3) All values of partial factors for actions or the effects of actions in accidental situations should normally be taken equal to 1,0. All values of partial factors for resistances should then be selected according to the particular circumstances of the accidental situation.'*

*NOTE The values of the partial factors may be set by the National annex.'*

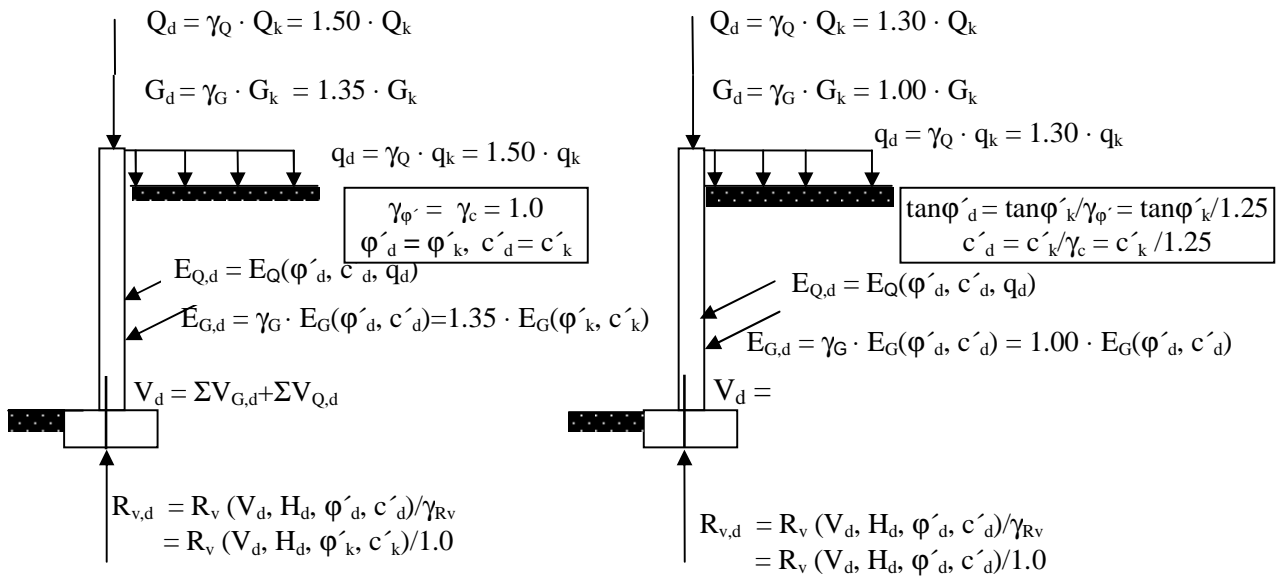

a) DA 1: Combination 1

b) DA 1: Combination 2

Note: for simplicity, only vertical equilibrium is considered and only unfavourable actions are shown.

Figure. 2. ULS in p&tds. Design Approach 1 - introduction of partial factors (recommended values) in the checking of ground bearing capacity (Frank et al., 2004).

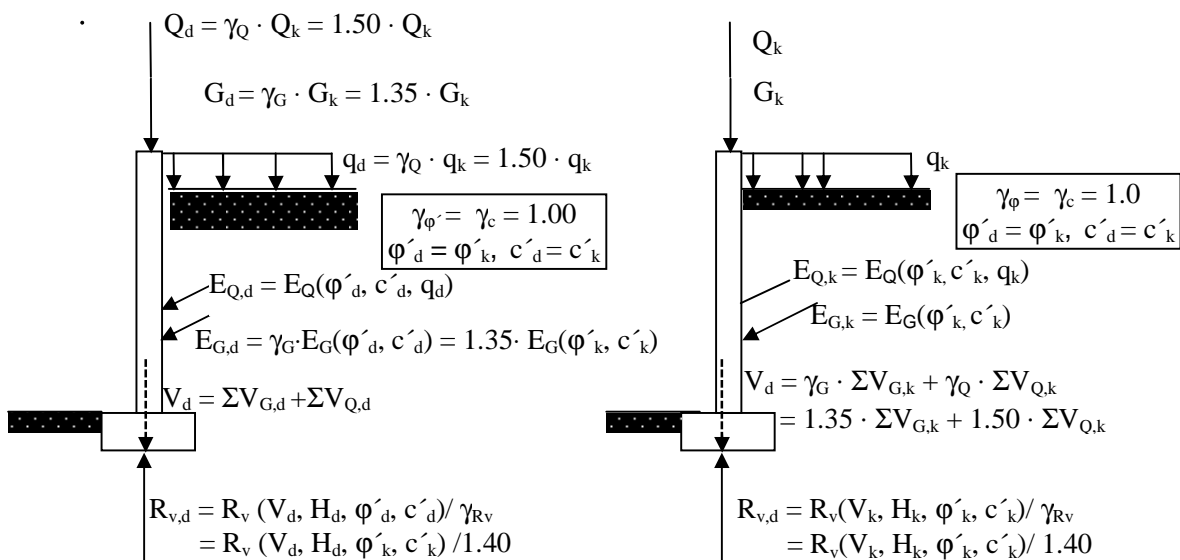

a) Factoring actions at the source (DA 2)

b) Factoring effects of actions (DA 2\*)

Note: for simplicity, only vertical equilibrium is considered and only unfavourable actions are shown.

Figure. 3. ULS in p&tds. Design Approach 2 - introduction of partial factors (recommended values) in the verification of ground bearing capacity (Frank et al., 2004).

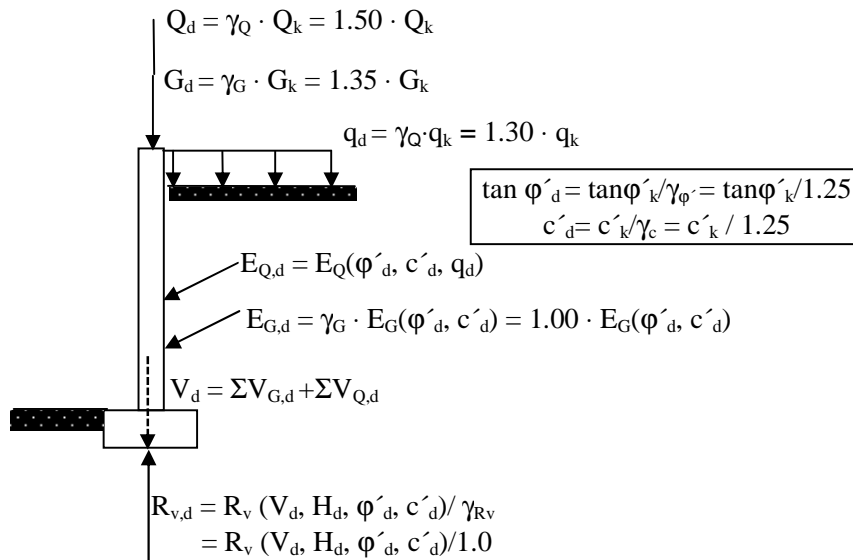

Note: for simplicity, only vertical equilibrium is considered and only unfavourable actions are shown.

Figure 4. ULS in p&tds. Design Approach 3 - introduction of partial factors (recommended values) in the verification of ground bearing capacity (Frank et al., 2004).

#### 4.5 Verification of serviceability limit states (SLS)

The main discussions during the development of Eurocode 7 were about the format for verifying ULS in permanent and transient situations. However, the verification of serviceability limit states (SLS) is an issue equally important in contemporary geotechnical design. This issue is fully recognised by Eurocode 7 which indeed often refers to displacement calculations of foundations and retaining structures, while common geotechnical practice mainly sought so far to master serviceability by limiting the bearing capacity or by limiting the shear strength mobilisation of the ground to relatively low values.

The verification of SLS in the real sense proposed by Eurocode 7 (prediction of displacements of foundations) is certainly going to gain importance in the near future. For the time being, it is an aspect which is too often neglected in common geotechnical practice.

Eurocode 7 – Part 1 repeats the formulation of EN 1990 (clause 2.4.8, EN 1997-1):

'(1) *P Verification for serviceability limit states in the ground or in a structural section, element or connection, shall either require that:*

$$E_d \leq C_d \quad (2.10)$$

*or be done through the method given in 2.4.8(4).*

(2) *Values of partial factors for serviceability limit states should normally be taken equal to 1,0.*

*NOTE The values of the partial factors may be set by the National annex.'*

with  $E_d$  the design value of the effect of actions and  $C_d$  the limiting value (serviceability criterion) of the design value of effect of actions.

At the same time, Eurocode 7 introduces immediately the possibility to keep the traditional approach mentioned above (clause 2.4.8 in EN 1997-1):

'(4) *It may be verified that a sufficiently low fraction of the ground strength is mobilised to keep deformations within the required serviceability limits, provided this simplified approach is restricted to design situations where:*

— *a value of the deformation is not required to check the serviceability limit state;*

— established comparable experience exists with similar ground, structures and application method.'

This clause is to be linked with the one dealing with the design methods of spread foundations (paragraph 6.4(5)P in EN 1997-1):

'(5)P One of the following design methods shall be used for spread foundations:

— a direct method, in which separate analyses are carried out for each limit state. When checking against an ultimate limit state, the calculation shall model as closely as possible the failure mechanism, which is envisaged. When checking against a serviceability limit state, a settlement calculation shall be used;

— an indirect method using comparable experience and the results of field or laboratory measurements or observations, and chosen in relation to serviceability limit state loads so as to satisfy the requirements of all relevant limit states;

— a prescriptive method in which a presumed bearing resistance is used (see 2.5).'

Indeed, the indirect method 'chosen in relation to serviceability limit state loads' comes to applying the traditional method of designing the bearing capacity of spread foundations, i.e. a simple calculation comparing the applied loads for serviceability limit states to a limit load divided by a global factor of safety high enough (usually around 3). Of course, as indicated in Eurocode 7, this can only be valid if there is no need to assess the settlement of the foundation.

Paragraph 2.4.8(2) of Eurocode 7 – Part 1, reproduced above, indicating that partial actors for SLS are normally taken equal to 1.0 (in other words that the design values of the various quantities are taken equal to their characteristic values), applies to the actions in the characteristic, frequent or quasi-permanent combinations (see EN 1990), as well as to the geotechnical properties, such as the modulus of deformation. It should be noted that, for determining the differential settlement for instance, sets of lower characteristic values and upper characteristic values can be chosen in order to take account of the ground variability.

With regard to the use of the combinations of actions for SLS, EN 1990 provides (in editorial notes) some guidelines which are summarised in table 5 (clause 6.5.3 in EN 1990).

Table 5. Recommended combinations of actions for checking serviceability limit states SLS

Combination of actions	Use according to EN 1990
Characteristic	Irreversible limit states
Frequent	Reversible limit states
Quasi permanent	Long term effect and appearance

When applying equation 2.10 of clause 2.4.8(1)P (see above), it appears that the frequent and quasi-permanent should be recommended; on the contrary, in the case of the alternative method allowed by 2.4.8(4), it seems that the characteristic (or 'rare') combination should be used, because the experience gained in the past was rather for loads near this type of combination.

The last general paragraph in Eurocode 7 – Part 1 about SLS states that (clause 2.4.8 in EN 1997-1):

'(5)P A limiting value for a particular deformation is the value at which a serviceability limit state, such as unacceptable cracking or jamming of doors, is deemed to occur in the supported structure. This limiting value shall be agreed during the design of the supported structure.'

The application of these general clauses is detailed further down in Eurocode 7 – Part 1 for each geotechnical structure (in the Sections for spread foundations, pile foundations, retaining structures, overall stability and embankments). It is interesting to note that the document insists several times on the difficulty to predict displacements with accuracy (in the present state of geotechnical engineering knowledge, of course!).

#### 4.6 Limiting values of displacements of foundations

The knowledge of limiting allowable displacements of foundations is a subject of prime importance, even though it is not often explicitly addressed. These limiting values depend primarily, of course, on the nature of the supported structure, but it has also been a point of interest for geotechnical engineering for a long time, as well (a summary of data collected for buildings and bridges is given e.g. by Frank, 1991).

The limiting values of movements of foundations are the subject, in particular, of clause 2.4.9, as well as of Annex H (informative) of Eurocode 7 – Part 1. It is noted that clause 2.4.9 contains 4 rather strong principles, i.e. paragraphs (1)P to (4)P. The first one says:

*'(1)P In foundation design, limiting values shall be established for the foundation movements.*

*NOTE Permitted foundation movements may be set by the National annex.'*

Furthermore, it seems that not only SLS are concerned (see above) but also ULS... (because movements of foundations can trigger an ULS in the supported structure).

Eurocode 7 gives a list of a certain number of factors which should be considered when establishing the limiting values of movements. It is important that these limiting values are established in a realistic manner, by close collaboration between the geotechnical engineer and the structural engineer. If the values are too much severe, they will usually lead to uneconomical designs.

Figure 5 defines the parameters used to quantify movements and deformations of structures. This figure, originally due to Burland and Wroth (1975) is reproduced in Annex H (informative) of Eurocode 7 – Part 1. Annex H quotes the following limits after Burland et al. (1977):

- for open framed structures, infilled frames and load bearing or continuous brick walls: maximum relative rotations between about 1/2000 and about 1/300 to prevent the occurrence of a SLS in the structure;
- for many structures, a maximum relative rotation  $\beta = 1/500$  is acceptable for SLS and  $\beta = 1/150$  for ULS;
- for normal structures with isolated foundations, total settlements up to 50 mm are often acceptable.

These values can serve as a guide, in the absence of other indications on the limiting values for the deformations of the structures.

#### 5. LIAISONS WITH OTHER CEN COMMITTEES

Inside the Eurocode system itself, there are, of course, many links between the different standards or parts of them. Eurocode 7 on Geotechnical design is more precisely linked to the following ones:

- EN 1990: 'Eurocode: Basis of structural design' which defines the various limit states and design situations to be checked, and gives the general rules for taking into account the actions on/from the structures and the geotechnical actions;
- EN 1998-5: Design of structures for earthquake resistance. Foundations, retaining structures and geotechnical aspects.

The other Technical Committees of CEN working on standards of interest for Eurocode 7, and for which coordination must be ensured are: CEN/TC 341 on 'Geotechnical investigation and testing', as mentioned earlier; CEN/TC 288 on 'Execution of geotechnical works'; CEN/TC 189 on 'Geotextiles and geotextile-related products'; CEN/TC 227 on 'Road materials'.

The standards on execution (TC 288) and on geotechnical tests (TC 341) are particularly important as they complement Eurocode 7, which is devoted only to design.

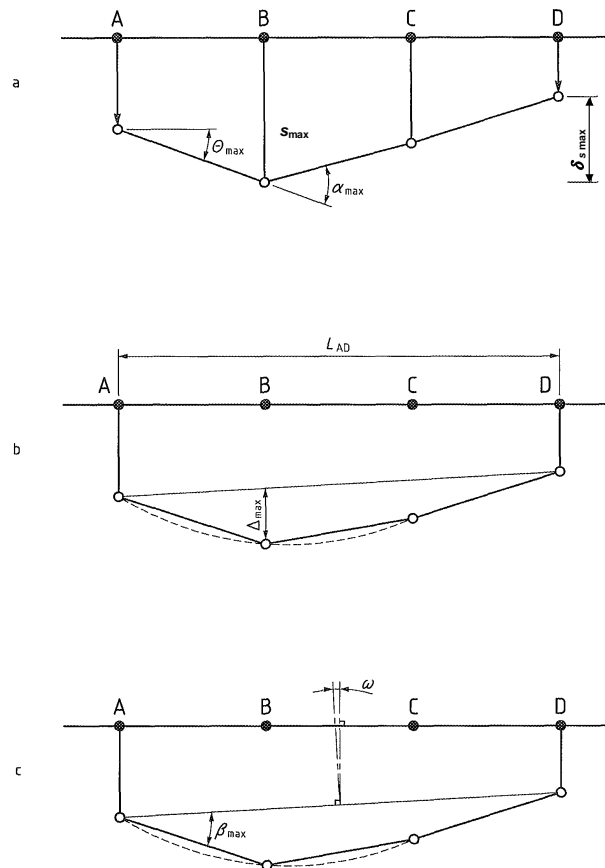

- a) definitions of settlement  $s$ , differential settlement  $\delta s$ , rotation  $\theta$  and angular strain  $\alpha$
- b) definitions of relative deflection  $\Delta$  and deflection ratio  $\Delta/L$
- c) definitions of tilt  $\omega$  and relative rotation (angular distortion)  $\beta$

Figure 5. Definitions of foundation movements and deformations of structures (CEN, 2004, after Burland and Wroth, 1975)

## 6. CONCLUDING REMARKS

The work for the elaboration of a common framework for geotechnical design throughout Europe, i.e. Eurocode 7, started nearly 40 years ago. Given the progress achieved, the corresponding standards/codes are now being enforced in the various countries.

Whatever the precise legal status of Eurocode 7 in the various countries, it proves to be very important for the whole construction industry. It is a tool helping European geotechnical engineers speak the same technical language and also a necessary tool for the dialogue between geotechnical engineers and structural engineers.

Eurocode 7 helps promote research. Obviously, it stimulates questions on present geotechnical practice from ground investigation to design models.

It is our belief that it is also very useful to many geotechnical and structural engineers all over the world, not only in Europe.



## 7. REFERENCES

- AFNOR (2009a) Calcul géotechnique - Ouvrages de soutènement - Écrans, *norme NF P94-282*, mars 2009, 182 pages.
- AFNOR (2009b) Calcul géotechnique - Ouvrages de soutènement - Remblais renforcés et massifs en sol cloué, *norme NF P94-270*, juillet 2009, 186 pages.
- AFNOR (2012) Justification des ouvrages géotechniques - Normes d'application nationale de l'Eurocode 7 - Fondations profondes, *norme NF P 94-262*, juillet 2012 (2e tirage, janvier 2013), 206 pages.
- AFNOR (2013) Justification des ouvrages géotechniques - Normes d'application nationale de l'Eurocode 7 - Fondations superficielles, *norme NF P 94-261*, juin 2013, 124 pages.
- AFNOR (2014) Justification des ouvrages géotechniques - Normes d'application nationale de l'Eurocode 7 - Ouvrages de soutènement – Murs, *norme NF P 94-281*, avril 2014, 93 pages.
- Anagnostopoulos, A. and Frank, R. (2012) EC7: Eurocode 7: an “umbrella code” its implementation, evolution and impact worldwide, *Proc 6th Panhellenic Conf on Geotechnical and Geoenvironmental Engng (6° Panhellenio Synedrio Geotechnikis kai Geoperivallondikis Michanikis)*, Volos, 29 September-1st October 2010, vol. 4, 2012, pp. 170-178. .
- Burland, J.B., Broms, B.B. and De Mello, V.F.B. (1977). Behaviour of foundations and structures. *Proc. 9th Int. Conf. Soil Mechs & Fdn Engng*, Tokyo 2: 495-546.
- Burland J.B. and Wroth C.P. (1975) Settlement of buildings and associated damage, Review Paper, Session V. *Proc. Conf. Settlement of Structures*, Cambridge: 611-654. Pentech Press, London.
- Burlon S., Frank R., Baguelin F., Habert J., Legrand S. (2014). "Model factor for the bearing capacity of piles from pressuremeter test results. A Eurocode 7 approach", *Géotechnique* 64, No. 7, 513–525 [<http://dx.doi.org/10.1680/geot.13.P.061>].
- CEN (1994). *Eurocode 7 Geotechnical design - Part 1: General Rules*. Pre-standard ENV 1997-1. European Committee for Standardization (CEN): Brussels.
- CEN (1999a). *Eurocode 7 Geotechnical design - Part 2: Geotechnical design assisted by Laboratory Testing*. Pre-standard ENV 1997-2. European Committee for Standardization: Brussels.
- CEN (1999b). *Eurocode 7 Geotechnical design - Part 3: Geotechnical design assisted by Field Testing*. Pre-standard ENV 1997-3. European Committee for Standardization: Brussels.
- CEN (2002). *Eurocode: Basis of structural design*. European standard, EN 1990 : 2002. European Committee for Standardization: Brussels.
- CEN (2004, 2013). *Eurocode 7: Geotechnical design - Part 1: General rules*, EN 1997-1:2004 (E), (F) and (G), November 2004, EN 1997-1:2004/AC (corrigendum), February 2009, NF EN 1997-1/A1 (Amendment for Section 8), 2013, European Committee for Standardization: Brussels.
- CEN (2007). *Eurocode 7: Geotechnical design - Part 2: Ground investigation and testing*. EN1997-2:2007 (E), March 2007, EN 1997-2:2004/AC (corrigendum), June 2010, European Committee for Standardization: Brussels.
- EC (2003a). *Guidance Paper L. Application and use of the Eurocodes*, ref.: CONSTRUCT 03/629 Rev.1 (27 November 2003), European Commission, Brussels.
- EC (2003b). *Commission recommendation of 11 December 2003 on the implementation and use of Eurocodes for construction works and structural construction products (2003/887/EC)*, Official Journal of the European Union, 19.12.2003, EN, L 332/62 & 63.
- EC 7 (1990). Eurocode 7: Geotechnics. Preliminary draft for the European Communities, *Geotechnik*, 1990/1.
- Frank R. (1991). Quelques développements récents sur le comportement des fondations superficielles. Rapport général, Session 3, *Comptes rendus 10ème Cong. Européen Méca. Sols et Tr. Fond.*, Florence, 26-30 mai, vol. 3, pp. 1003-1030. (English version: Some recent developments on the behaviour of shallow foundations. General report, *Proc. 10th European Conf. Soil Mechs & Fdn Engng*, Florence, 26-30 May, vol. 4, pp. 1115-1141, 1994).

Frank R., Bauduin C., Driscoll R., Kavvadas M., Krebs Ovesen N., Orr T. , Schuppener B. (2004). *Designer's guide to EN 1997 Eurocode 7 – Geotechnical design*, Thomas Telford, London, 216 pages.

Frank, R. & Magnan J.P. (1999). Quelques réflexions sur la vérification des états limites ultimes suivant l'Eurocode 7 (in French - A few thoughts about ultimate limit states verifications following Eurocode 7). Workshop on the Eurocodes, *Proc. 12th European conf. soil mechs. & geot. engng*, 7-10 June, Amsterdam, vol. 3: 2179-2183.

Huybrechts N., Patel D., De Vos M. (2005). *The use of the observational method*. Final Report WP3 on Innovative design methods in geotechnical engineering European network 'GeoTechNet'.